

Technical Specification Sheet

Attenzi / Tribezi Tank

3 in 1 Boiling Hot Water Tank

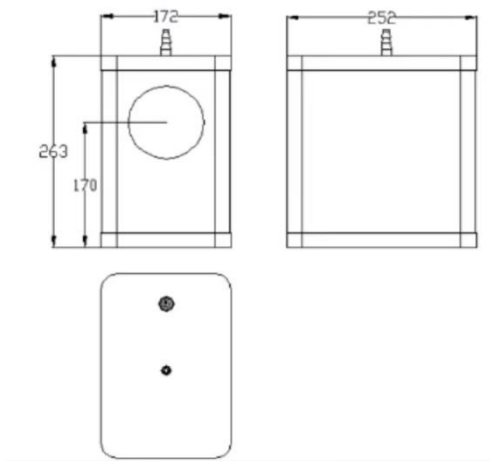

Additional Features/Benefits

6 Preset Temperatures on tank - 98 Degrees Max, 97 / 95 / 90 / 85 and 75 degrees

Suitable for all plumbing systems

Eco mode and Filter reminder

Warranty

2 years manufacturing on tank, 6 months on Filter (Filter must be changed every 3-6 months to ensure this doesn't invalidate warranty on tank) **Customers must register the warranty as per the info on the tank / card**

Care & Maintenance

Reginox recommends cleaning your tap regularly with non-abrasive cleaners. Warm, soapy water would be best.

Tank Specification

Finish	Black Coating
Body	Stainless Steel
Connections	Inlet ¼" push fit, Outlet 2 step Plastic barb Connector Pushes and locks (JG snap
Push Fit Connections	3/8" JOHN GUEST TYPE SNAP FIT GROOVE SHAFT

Tank Dimensions

Height (mm)	263
Width (mm)	172
Length (mm)	252

Tank Info

1.5Kw element- 3L Tank Capacity	Filter Change reminder and Eco Mode.
---------------------------------	--------------------------------------

Improved insulation for better thermal energy saving properties and less boiling noise.

Additional Improvements

Filter has had a higher phosphate level added to help improve slightly the water quality going to the tank, the filter will help against hard water / LimeScale but will not stop it!

Improved Thermistor manufactured using titanium, helping lower lime scale build up.

Universal Quick Fit Connections on tank make it even simpler to install

Box Dimensions

Weight (kg)	4.3
Box Dimensions (mm)	Height 465mm, Width
Packed Weight (kg)	10

Certificates

Tank	Tap