

Technical Specification Sheet

ATTENZI CH

3 IN 1 TAP - including tap/tank/filter/Descaling Kit

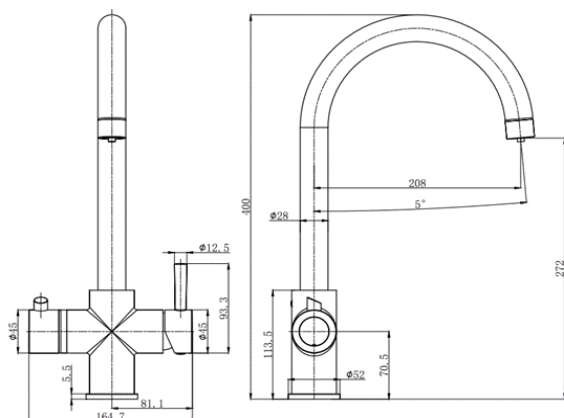

Tap Specification

Finish	Chrome
Body	Brass
Fitting	Deck Mounted
Connections	BSP G1/2" Flexible Hoses
Spout Rotation (°)	360

Tap Dimensions

Tap Hole Size (mm)	35
Height (mm)	400
Base Width (mm)	60
Reach (mm)	208

Tank Dimensions

Height (mm)	263
Width (mm)	172
Length (mm)	252

Bar Pressure

Minimum Pressure	1
Maximum Pressure	6

Tank Info

1.5Kw element- 3L Tank Capacity	Filter Change reminder and Eco Mode.
---------------------------------	--------------------------------------

Flow Rates

@ 0.5 bar	@ 1 bar	@ 2 bar	@ 3 bar
(mixer) 4.8 l/m (Boiling) 1.9 l/m	(mixer) 6.7 l/m (Boiling) 2.7 l/m	(mixer) 9.3 l/m (Boiling) 3.8 l/m	(mixer) 11.4 l/m (Boiling) 4.7 l/m

Additional Features/Benefits

Insulated spout and handle for anti scald

Plastic / Carbon fibre filter

6 Preset Temperatures on tank - 98 Degrees Max, 97 / 95 / 90 / 85 and 75 degrees

Suitable for all plumbing systems

Warranty

3 Years manufacturing on tap, 2 years manufacturing on tank, 3-6 months on Filter (Filter must be changed every 3-6 months to ensure this doesn't invalidate warranty on tank) **Customers should register the warranty as per the info on the tank / card**

Care & Maintenance

Reginox recommends cleaning your tap regularly with non-abrasive cleaners. Warm, soapy water would be best.

All pressures are in bar.

Dimensions supplied are nominal and subject to tolerance.

Inclusion of aerator (if supplied) or restrictors (supplied separately) will affect flow rate result.

Performance details are based on trials under test conditions and are for guidance only,

The manufacturer reserves the right to change product specification without prior notice.

Box Dimensions

Weight (kg)	8
Box Dimensions (mm)	Height 465mm, Width 255mm, Length 355mm
Packed Weight (kg)	10
EAN Number	0658556023372