

# Technical Specification Sheet

## ALTUS CH

*Chef mixer tap with black spout*

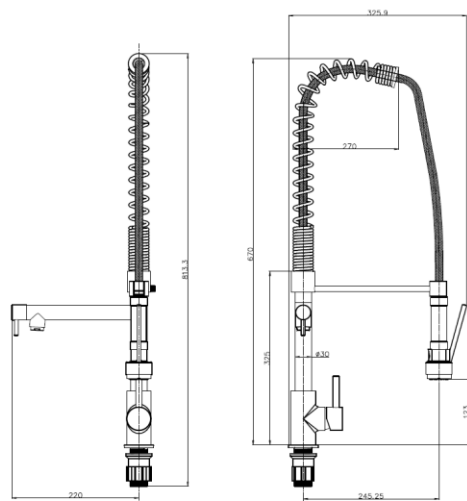

### Specification

Finish	Chrome
Body	Brass, Stainless Steel
Fitting	fixation kits/inlet hoses
Connections	
Spout Rotation (°)	360

### Dimensions

Tap Hole Size (mm)	35
Height (mm)	670
Base Width (mm)	
Reach (mm)	325.9
Weight (kg)	3.35
Box Dimensions (mm)	750 x 330 x 65
Packed Weight (kg)	3.5

### Bar Pressure

Minimum Pressure	0.5
Maximum Pressure	5
Maximum Static Pressure	8
Maximum Temperature (°C)	70

### Flow Rates

@ 0.1 bar	@ 0.5 bar	@ 1 bar	@ 3 bar
	2.7 L/m	4.2 L/m	7.5 L/m

### Additional Features/Benefits

Chef style flexible hose

Black nozzle

Not Pull out - useable length of hose 600mm

EAN Number

5060916361751

### Warranty

10 Year Warranty (Casting Only)

### Care & Maintenance

Reginox recommends cleaning your tap regularly with non-abrasive cleaners. Warm, soapy water would be best.

All pressures are in bar.  
 Dimensions supplied are nominal and subject to tolerance.  
 Inclusion of aerator (if supplied) or restrictors (supplied separately) will affect flow rate result.  
 Performance details are based on trials under test conditions and are for guidance only,  
 The manufacturer reserves the right to change product specification without prior notice.

### Certifications