

# Technical Specification Sheet

## MARTA CH

Pull out spray mixer tap

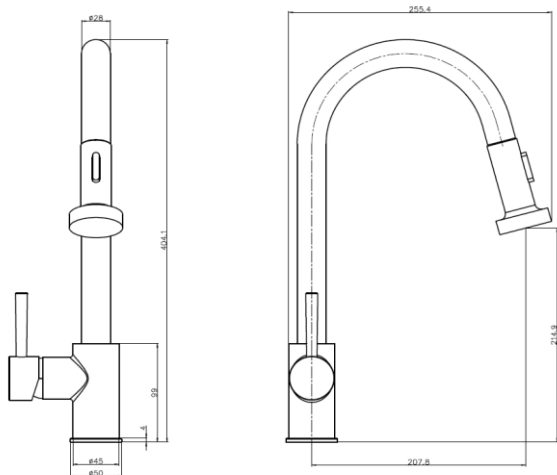

### Specification

Finish	Chrome
Body	Brass , Stainless Steel
Fitting	fixation kits/inlet hoses
Connections	
Spout Rotation (°)	360

### Dimensions

Tap Hole Size (mm)	35
Height (mm)	404
Base Width (mm)	50
Reach (mm)	207
Weight (kg)	2.4
Box Dimensions (mm)	420 x 250 x 65
Packed Weight (kg)	3

### Bar Pressure

Minimum Pressure	0.5
Maximum Pressure	5
Maximum Static Pressure	8
Maximum Temperature (°C)	70

### Flow Rates

@ 0.1 bar	@ 0.5 bar	@ 1 bar	@ 3 bar
n/a	2.4 L/m	3.6 L/m	6.6 L/m

### Additional Features/Benefits

Pull out spray

1.2m long hose - useable length for pull out 600mm

EAN Number 5060916361782

### Warranty

10 Year Warranty (Casting Only)

### Care & Maintenance

Reginox recommends cleaning your tap regularly with non-abrasive cleaners. Warm, soapy water would be best.

All pressures are in bar.  
Dimensions supplied are nominal and subject to tolerance.  
Inclusion of aerator (if supplied) or restrictors (supplied separately) will affect flow rate result.  
Performance details are based on trials under test conditions and are for guidance only,  
The manufacturer reserves the right to change product specification without prior notice.

### Certifications