

BRISTAN

Installation Instructions Pivot Tap Range

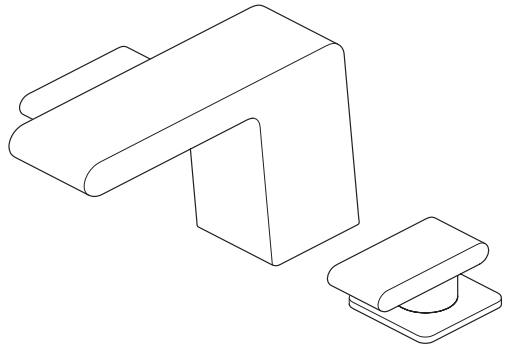

Models covered:

PIV 3HBAS C, PIV 3HBF C,
PIV 5HBSM C

Please keep this booklet for future reference.

Installer, when you have read these instructions please ensure you leave them with the user.



Contents

Thank you for choosing Bristan, the UK's leading taps and showers expert.

We have designed this product with your enjoyment in mind. To ensure that it works to its full potential, it needs to be fitted correctly. These fitting instructions have been created to give you all of the information you need and, if you need any further help, please do not hesitate to contact us.

Important Safety Information.....	3
General Information	4
Specifications	4
Dimensions.....	5-6
Installation Requirements	7
Installation.....	8-11
3 Hole Basin Mixer & Bath Filler	8-9
5 Hole Bath Shower Mixer.....	10-11
Maintenance	12
Troubleshooting.....	13
Guarantee	14-15

Important Safety Information

- Please read these instructions thoroughly and retain for future use.
- All products manufactured and supplied by Bristan are safe provided they are installed, used correctly and receive regular maintenance in accordance with these instructions.
- **If you are in any doubt about your ability to install this product safely you must employ the services of an experienced qualified plumber.**
- This product needs to be installed in accordance with, and meet the requirements of the Water Supply (Water Fittings) Regulations 1999 and Scottish Byelaws 2004.
- Remove all packaging and check the fitting for damage before starting installation.
-  **Warning:** Before starting any installation please consider the following: before drilling into walls, check that there are no hidden electrical wires, cables or water supply pipes. This can be checked with the aid of an electronic detector.
- If power tools are used do not forget to:
 - Wear eye protection
 - Unplug equipment after use
- **Important:** Remember to turn off the mains water supply before connecting to any existing pipe work. Fitting isolating valves to the inlet feeds is recommended for ease of maintenance.
-  **Warning:** Before installing this product it is essential that you thoroughly flush through the pipework in order to remove any remaining swarf, solder, etc. Failure to carry out this procedure could cause problems or damage to the workings of the tap.
- Take care when handling the 'flexible connecting pipes', do not bend, twist or crush them. Only tighten the pipes by hand.
- Do not crush or kink the shower hose, this could damage the hose and cause leaks.
- This product must not be modified in any way as this will invalidate the guarantee.

General Information

This product has been tested to the Water Regulations Advisory Scheme (WRAS) and satisfies the requirements of the Water Supply (Water Fittings) Regulations 1999 and current bylaws. For full Installation Requirements & Notes (IRN) please visit www.wras.co.uk/directory.

Designed to comply with BS EN 200 for combination taps to be used within systems designed to BS 8558.

BS 8558 recommends hot water should be stored and distributed at a temperature of not less than 60°C which will help minimise the build-up of lime scale in hard water areas.

If installing this product on a low pressure (tank fed) system please see specifications table below to determine the minimum distance required from underside of the cold water tank to the outlet.

These taps and mixers should be installed in compliance with the Water Regulations. Where the supplies are unbalanced, i.e. Hot water from cylinder tank / cold from the mains, approved check valves must be fitted in the supply pipes.

For further details contact your Local Water Authority.

Specifications

Product Code	Working pressure		Inlet	Minimum distance from cold water tank to outlet (metres)
	Min	Max		
PIV 3HBF C	0.2	5.0	3/4" BSP Threaded Tail	2
PIV 3HBAS C	0.2	5.0	1/2" BSP Threaded Tail	2
PIV 5HBSM C	0.5	5.0	3/4" BSP Threaded Tail	5

Maximum static pressure- 10.0 bar

System Requirements:

Gravity fed hot & cold (Equal pressures)

Gravity fed hot & cold (Differential pressure, maximum ratio 5:1)

Unvented systems

Instantaneous water heater (Combination boiler)

Dimensions

3 Hole Basin Mixer

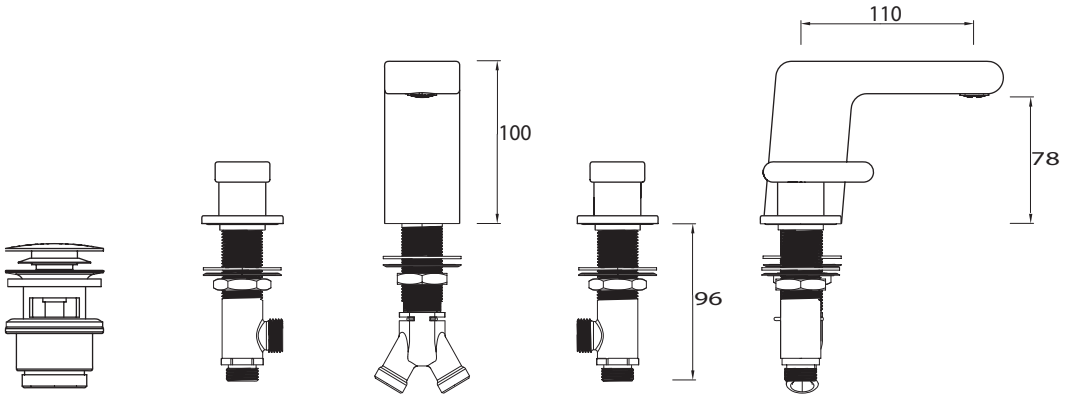

3 Hole Bath Filler

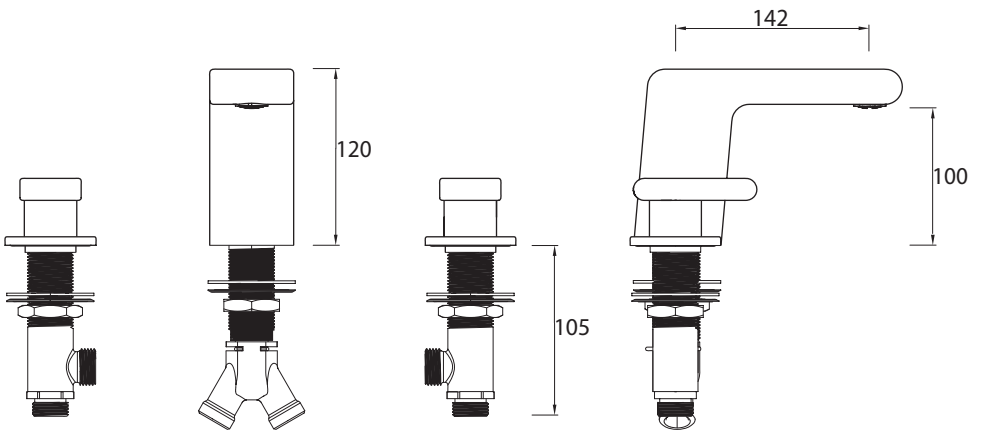

Dimensions are approximate and in millimetres.

Need help? Give us a call on 0844 701 6273 and speak to one of our trained advisers.

Dimensions Cont.

5 Hole Bath Shower Mixer

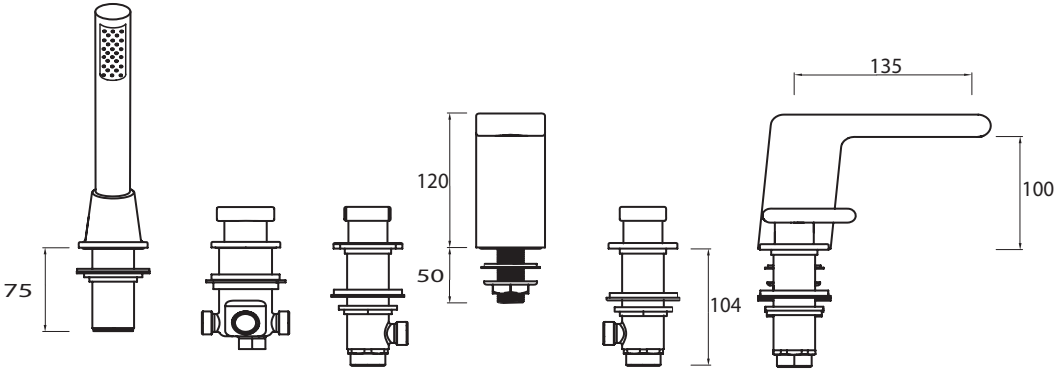

Dimensions are approximate and in millimetres.

Installation Requirements

Flexible Connecting Pipes

Care must be taken when connecting the flexible connection pipes to the household pipework to ensure they do not bend sharply and kink or twist.

See below for recommended ways to fit the flexible connecting pipes.

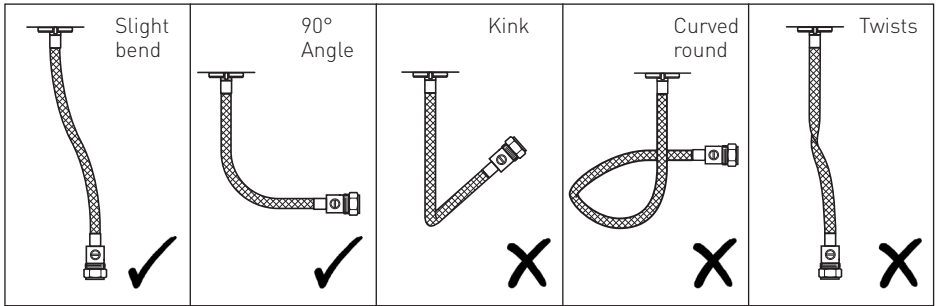

 **Important:** Failure to follow these guidelines may result in poor performance and damage to the flexible connecting pipes.

 **Important:** Full access must be made available on installation for future maintenance/ servicing purposes.

Installation

3 Hole Basin Mixer & Bath Filler

1. With the backnut, metal and rubber washer fitted to the side body threaded tail, feed the side body through the hole in the basin/ bath from underneath and secure in position by screwing the plinth onto the side body valves, ensuring that the washers are fitted between the plinths and the basin/ bath to create a water tight seal.

2. Secure the side bodies to the basin/ bath by tightening the backnuts and the washers up to the underneath of the basin/ bath.

3. Screw the valve shrouds onto the side body valves.

4. Fit the handles onto the valves and secure by tightening the grub screws. Push fit the caps.

5. Remove the washers and the backnut from the spout threaded tail. Fit the spout to the basin/ bath ensuring that the washer is fitted between the spout and the basin/ bath to create a water tight seal. Secure the spout to the basin/ bath using the washers and metal backnut. Tighten the backnuts onto the threaded tail. A suitable spanner may be required to fully tighten the backnut.

6. Connect the hot and cold water supplies to the side bodies (hot to the left, cold on the right hand side).

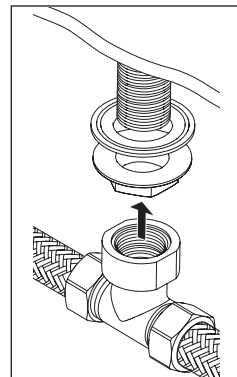
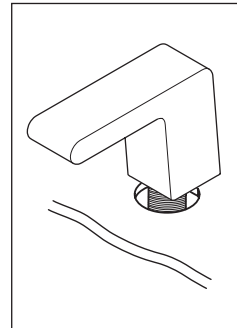
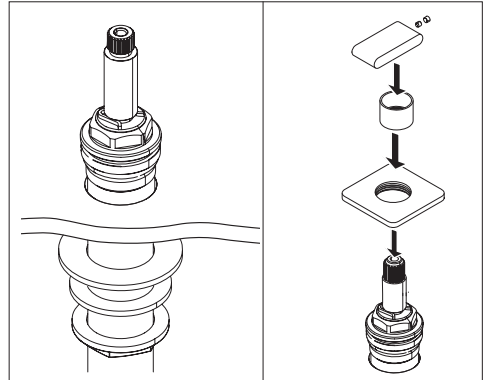

Installation Cont.

3 Hole Basin Mixer & Bath Filler Cont.

7. Attach the T- joint assembly and connect to the side bodies (hot on the left, cold on the right when viewed from the front), by using the flexi tails supplied.

8. Fit the clicker waste (basin mixer only) ensuring the rubber washer is fitted between the basin and the waste. Place the other rubber washer under the basin and secure by tightening the backnut, in order to fill the basin, the button in the middle of the waste needs to be pressed down. To release the water, press the button again.

9. Turn on both water supplies, operate both handles, letting the water flow for a few minutes to flush through the system.

10. Check all joints and connections for any leaks.

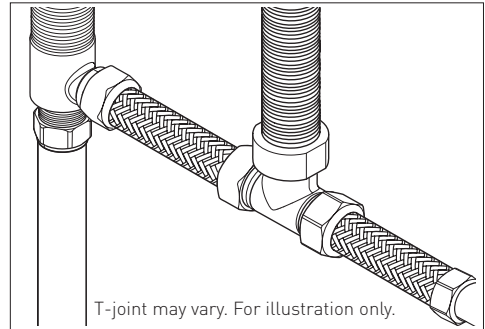

Installation Cont.

5 Hole Bath Shower Mixer

1. With the backnut, metal and rubber washer fitted to the side body threaded tail, feed the side body through the hole in the bath from underneath and secure in position by screwing the plinth onto the side body valves, ensuring that the washers are fitted between the plinths and the bath to create a water tight seal.

2. Secure the side bodies to the bath by tightening the backnuts and the washers up to the underneath of the bath.

3. Screw the valve shrouds onto the side body valves.

4. Fit the handles onto the valves and secure by tightening the grub screws. Push fit the caps.

5. Remove the washers and the backnut from the spout threaded tail. Fit the spout to the bath ensuring that the washer is fitted between the spout and the bath to create a water tight seal. Secure the spout to the bath using the washers and metal backnut. Tighten the backnuts onto the threaded tail. A suitable spanner may be required to fully tighten the backnut.

6. Fit the diverter to the bath. Remove the diverter handle by loosening the grub screw. With the backnut and rubber washer fitted to the diverter threaded tail, push the diverter body up through the underside of the bath. Screw the plinth and the shroud onto the diverter threaded tail. Fit the diverter handle and tighten the grub screw. Tighten the backnut underneath to secure the diverter body in position.

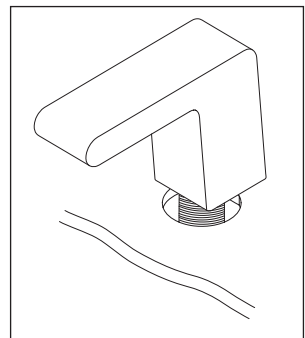
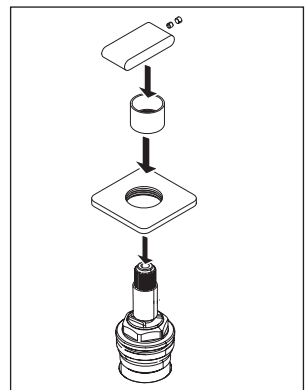
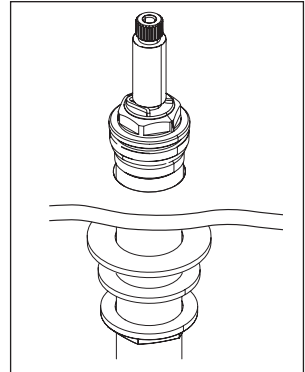

Installation Cont.

5 Hole Bath Shower Mixer Cont.

7. Connect the side bodies to the diverter using the flexi tails supplied.

8. Connect the spout to the diverter using the flexi tail supplied.

9. Fit the shower head holder to the bath. Remove the backnut and the washers and feed the threaded tail through the hole in the bath. Secure in place by screwing the backnut onto the threaded tail ensuring the washers are fitted.

10. Connect the water supplies to the side bodies (hot on the left, cold on the right when viewed from the front)

11. Feed the shower hose through the shower head holder and screw the connecting nut onto the bottom of the hose. Connect the hose to the diverter body.

12. Fit the shower head to the hose ensuring the small sealing washer is fitted.

12. Turn on both water supplies, operate the handle in both directions, letting the water flow for a few minutes to flush through the system.

13. Check all joints and connections for leaks.

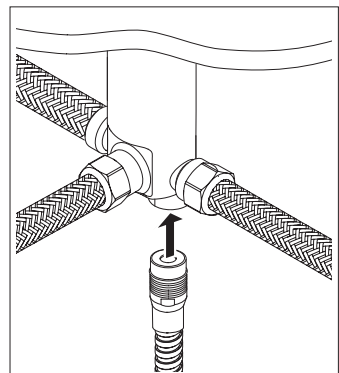
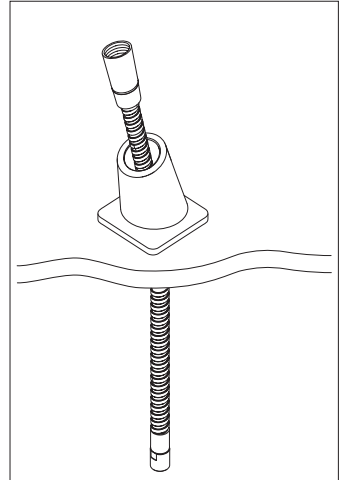

Maintenance

General Cleaning

Your product has a high quality finish and should be treated with care to preserve the visible surfaces. All surfaces will wear if not cleaned correctly, the only safe way to clean your mixer is to wipe with a soft damp cloth. Stains can be removed using washing up liquid. All bath cleaning powders and liquids will damage the surface of your fitting, even the non-scratch cleaners.

Note: Never use abrasive detergents or disinfectants or those containing alcohol, hydrochloric acid or phosphoric acid.

Cleaning the Cartridge

Before carrying out any maintenance, turn off the both water supplies or close any isolating valves.

Remove the cap and loosen the grub screw using a 2.5mm hexagonal key. Remove the handle. Unscrew the valve shroud and the plinth. Remove the valve.

Wash the valve with clean running water and make sure that any debris has been removed.

If necessary replace the valve using parts supplied by Bristan only.

Lightly grease the seal (only use silicone grease), replace the valve, plinth, valve shroud and the handle.

Tighten the grub screw and push fit the cap.

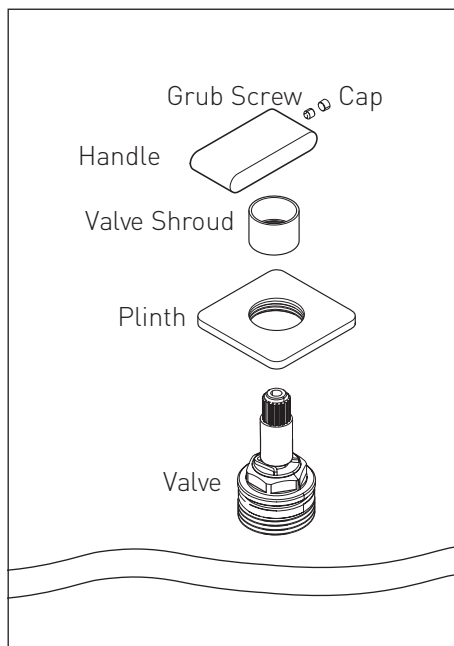

Troubleshooting

Symptom	Cause	Remedy
No flow or low flow rate	Partially closed isolation valve.	Open isolation valve.
	Instantaneous water heater cycles on and off as flow rate or pressure is too low.	Increase water flow rate or pressure through system to meet required minimum working pressure of tap.
	Head of water is below the minimum distance required.	Refer to 'Specifications' on page 4.
	Hot or cold water being drawn off elsewhere causing pressure changes or instantaneous boiler temperature changes.	Do not use other water outlets when using the taps.
	Airlock or partial blockage in the supply pipework.	Flush through pipework to ensure removal of debris and any airlocks.
Water dripping from taps	This is normal for a short time after using the taps.	This is caused by capillary action, the build up of water in the tap body.
	If water continues to drip, possible build up of debris / limescale in the valve.	Remove and clean the cartridge, refer to 'Maintenance' section on page 12 before removing the valve.
Taps do not turn on	Closed isolation valve.	Open isolation valve.
	Water supplies to the tap turned off.	Turn on both water supplies to the tap.

Guarantee

At Bristan, we want to make things as easy as possible for our customers. That's why we design products that are easy to fit and use, and that are quality tested to make sure they won't let you down. It's also why we offer solid guarantees on all products, effective from the date of purchase, to give you peace of mind.

Bristan's Bathroom Taps are covered by a **5 year guarantee**. This also includes **5 year labour cover** * (subject to registration) which means that, in the unlikely event that there is a problem in the first year after purchase, we'll send one of our expert engineers to fix it.

*Labour is provided by an approved Bristan Care engineer or appointed representative. The guarantee only applies to products with a manufacturing fault. There will be a call out charge for any incidents where no fault has been found with the product, or if the issue is due to poor installation or maintenance.

Guarantee Terms and Conditions

This guarantee is in addition to your statutory and other legal rights and is subject to the following conditions:

- The product was purchased within the United Kingdom or Republic of Ireland.
- The guarantee applies solely to the original purchaser with proof of purchase.
- The installation must allow ready access to all products for the purpose of inspection, maintenance or replacement.

- Repair under this guarantee does not extend the original expiry date. The guarantee on any replacement parts or product ends at the original expiry date.

- Any part found to be defective during the guarantee period will be replaced without charge, providing that the product has been installed in accordance with the instructions given in this guide and used as the manufacturer intended.

The guarantee does not cover:

- Damage or defects caused by;
 - General wear and tear (including special non-chrome finishes; components such as filters, seals, 'O' rings and washers)
 - Incorrect installation
 - Repair using non-Bristan parts
 - Accidental or wilful misuse
 - Corrosion and the use of inappropriate cleaning products
 - System debris including the build up of limescale (which can be controlled through regular servicing and maintenance)
- Compensation for loss of use of the product or consequential loss of any kind.

In the interests of continuous product improvement, Bristan reserves the right to alter product specifications without notice.

The Bristan Product Guarantee does not affect your statutory rights as a consumer.

Guarantee & Service Policy

• Need help?

If this product does not function correctly when first used, contact **Bristan Care Customer Service on 0844 701 6273** where our expert team of advisors will be able to offer you help and advice.

• Problems during the guarantee period

In the unlikely event that you encounter any problems with the product during the guarantee period, contact **Bristan Care Customer Service on 0844 701 6273** with your proof of purchase and we will work to resolve the problem quickly.

Bristan Care Customer Support

Bristan customers also benefit from the support of Bristan Care, our comprehensive customer support package which offers:

Technical support hotline

(Tel: 0844 701 6273) with access to fully trained advisers who can offer installation advice, talk you through quick maintenance checks, or recommend the best course of action to fix any problems with a product.

Expert advice

Find easy to follow 'how to' video guides and technical FAQs online at www.bristan.com. Our guides take you step-by-step through many product installations and you can find plenty of easy guides to quick product fixes and servicing.

Spare parts

We hold thousands of spares and we keep them for discontinued products for over seven years. Spares can easily be ordered online at www.bristan.com and are dispatched the same day.

Expert plumbing engineers

If we can't solve the problem over the 'phone or with a spare part, then we'll send out one of our Bristan Care engineers to take a look. Bristan Care engineers provide free support for products that are within guarantee, but are also available to service products that are out of guarantee for a small charge. For details, please call **Bristan Care Customer Service on 0844 701 6273**.

Part Numbers: **PIV BOOK 3**

Issue: D1

BRISTAN

Bristan Group Ltd.
Birch Coppice Business Park
Dordon
Tamworth
Staffordshire
B78 1SG
Web: www.bristan.com
Email: enquire@bristan.com

A Masco Company

Useful contact details:

Customer Service:

0844 7016273

Customer Service Email:

Customercare@bristan.com

Customer Service Fax:

0844 7016275

Reception:

0844 7016274

Join us on...

