



Instruction manual for induction wok

Model code: C930I



Dear Customer,

We thank you and congratulate you on granting us your preference, by purchasing one of our products. We are sure that this new appliance, manufactured with quality materials, will meet your requirements in the best possible way.

The use of this new equipment is easy. However, we invite you to read this booklet carefully, before installing and using the appliance. This booklet gives the right information on the installation, use and maintenance, as well as useful advice.

CAPLE

ENVIRONMENT PROTECTION

This product complies with EU Directive 2002/96/EC.

The crossed-out dustbin symbol reported on the appliance indicates that the appliance must be disposed of separately from other domestic refuse at the end of its useful life. It must therefore be delivered to a waste recycling centre specifically for electric and electronic equipment or returned to the retailer at the moment of purchase of a new equivalent appliance.



The user is responsible for delivering the appliance to the appropriate collection centre at the end of its useful life, failure to do so may result in a fine, as provided for by laws governing waste disposal.

Differential collection of waste products for eventual recycling, treatment and environmentally friendly disposal helps reduce possible negative effects on the environment and health, and also enables the materials making up the product to be recycled.

For more detailed information on the available refuse collection systems, refer to the local Municipal Solid Waste disposal centre or the shop where the product was purchased.

Producers and importers are responsible for fulfilling their obligations as regards recycling, treatment and environmentally friendly disposal by directly or indirectly participating in the collection system.

DESCRIPTION

DIMENSIONS: 520 X 400

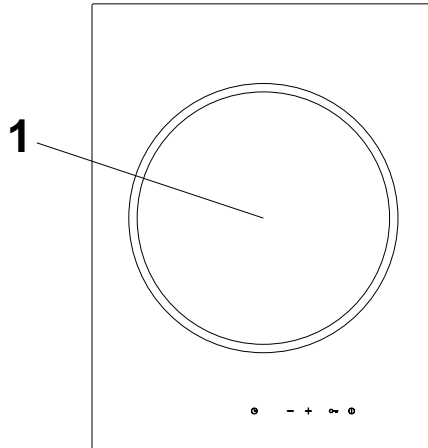

1 - Cooking area Ø 300 (2400 W - Booster 3000 W)

CONTROL DESCRIPTION

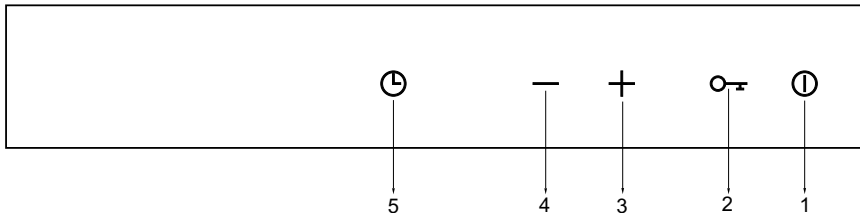

- 1 Switching on - switching off
- 2 Controls functions lock
- 3 Increase temperature/timer
- 4 Decrease of temperature/timer
- 5 Timer activation

SAFETY AND CARE DIRECTIONS

Correct use.

- To avoid damages to persons and fittings read carefully this directive before use the hob for the first time.
- Use the hob after embedding it correctly; it is important to avoid the contact with electric wire components.
- The hob is meant to be used only in domestic background not in the industrial field.
- Use the appliance only to prepare dishes; other uses at consumer risk, they can be dangerous. The manufacturer do not answer to damages caused by an incorrect use of the appliance.

If there are children at home.

- Use controls lock so as the children can not switch on the hob or modify its setting.
- The appliance must be used only by adults, who are able to understand the indications on this directive. Often children can not perceive the damages of a functioning hob. Keep an eye on the children carefully.
- Grown-up children can use the appliance only if they have been educated to use it carefully and in absolute security and if they know the possible damages caused by an incorrect usage.
- Do not permit to children to play with the appliance.
- The hob warms and stays warm for some time also after the switching off. For this reason children must be taken far from the appliance to avoid every scorch risk.
- Take attractive objects far from children and the hob, because they could lead them to approach the appliance with consequent scorch risks.
- Make sure that children could not have the possibility to upset hot pots or pans. Danger of explosion and fire, in addition with scorch. In the market there is a special pan support which could be useful to reduce accident risks.
- Children should be taken far from the packaging, because some of its components (in plastic or polystyrene) are dangerous (choking danger). Provide immediately for the elimination of the packaging.

Advice to better use the hob.

- Take care not to throw objects or cutlery on the ceramic surface. Also light objects (i.e. a salt-cellar) might crack or damage the ceramic plate.

- Do not use pots or pans with rough bottom (i.e. cast iron), because they could scratch the surface of the hob. Also grains of sand could cause scratches.
- Make sure that sugar, liquefied or solid, plastic or silver paper do not be leant on the hot cooking areas. These materials melt, stick on the surface and when they cool they can crack, break or damage permanently the ceramic surface. If these substances inadvertently reach the hot cooking areas, switch off the hob and eliminate them with a spatula as soon as possible, when the appliance is already hot. **Attention: since the cooking areas are very hot there is the possibility to scald yourself.**
- To avoid a risk of dishes remains burning, get rid of them immediately in case they overflowed in the surface during the cooking; make sure that the pot bottom is not grease, but clean and dry before leaning it on the hob.
- Never use vapour devices. The vapour pressure could damage permanently surfaces and components of devices, for which the manufacturer will not be responsible.
- Never lean too hot pots or pans on the control panel. The electronics situated under the panel could be damaged.
- **If under the embedded appliance there is a drawer, take care of that the distance between the drawer, and so its content, and the lower side of the appliance is enough. On the contrary the aerification of the hob is not warranted.**

To avoid burns.

- When functioning the appliance is too hot and maintains the temperature for some minutes after the switching off. Only when the afterheat lights go off there is no more danger of burns. Pay attention to children at home, they must not approach the still hot hob.
- Always use the proper knobs or pot holders to move or to put pots and pans on the hob. The knobs and pot holders material must not be wet or damp. The dampness increases the heat conductivity and so the risks of burns.
- Do not heat closed vessels, i.e. tin vessels, on the cooking areas. The resulting overpressure could cause the explosion of this material. Burn and hurt danger.
- Do not use the appliance as a rest surface and in particular do not lean on metallic objects. If the hob is unintentionally switch on or if the cooking

SAFETY AND CARE DIRECTIONS

- areas after heat is already functioning there is the risk that the resting object, depending on its material, heats (burn danger), start melting or burning.
 - Do not cover the hob with a cloth or a protective film. The hob could be hot; burning danger.
 - Stay near the hob when using fats and oils because when they overheat, they can start burning and ignite also the cooker hood. Fire danger.
 - If fats and oils used to cook start burning, do not try to extinguish the fire with water. Smother the fire with a blanket or an extinguisher.
 - Do not cook flambé dishes under the cooker hood. Flames could reach the cooker hood and burn it.
- The main sheathing could be damaged. Electrical shock danger.
- Warm sufficiently the dishes. Germs present in the food are eliminated only at high temperature and in a long period of time.
 - Do not use plastic or tin foil dishes. High temperature could melt these materials. Fire danger.
 - Do not approach to the functioning hob magnetic objects like credit cards, floppy disks, calculators. Their functions could be compromised.
 - Do not put canisters, liquids or other flammable materials in drawers under the appliance. The drawer's cutlery tray, if present, should be in heat resistant material.

If there is a faulty appliance.

- If the consumer finds an anomaly in the appliance, disconnect the electricity of the hob. If the appliance is not definitively setted and linked up, detach also the stoker wire from the electric system. For this purpose do not hold the wire but the plug, if present. Call the technical assistance. Pay attention not to connect the appliance to the electrical system before repairing it.
- If there are cracks on the ceramic surface, disconnect the electricity of the appliance. Electrical shock danger.
- **Repairs have to be made only by skilled and authorized staff. Uncorrect repairs could be cause of danger and further damage the appliance. Never undo the appliance wrapping.**
- Repairs on the appliance during the warranty period can be done only by the firm technical assistance, otherwise the consumer will not have the right of calling for the following damages.

Further damages.

- **Only for pacemaker carrier: to consider that near the functioning appliance there is a electromagnetic field, which could compromise the pacemaker performance. For doubts regarding the pacemaker apply its producer or the doctor.**
- Take care of positioning the dishes in the centre of the cooking area, so that the pot's backside can cover all the electromagnetic field.
- Using a socket near the appliance, make sure that the supply wire do not touch the hot hob.

INSTALLATION

General Instructions.

- The installation and the connection must be done only by a qualified electrician. Refer only to an electrician who knows local and supplemental rules promulgated by local electrical firm. Take care of that the work is made in respect of these rules. The producer is not responsible for damages caused by wrong embedding or connection of the appliance.
- The appliance electrical security is guaranteed only if this is connected to a regular grounded conductor. It is important to check that this condition is satisfied because it is a fundamental condition. If in doubts call a skilled technician to check the installation. The producer do not respond for damages caused by the absence or interruption of the grounding conductor.
- The appliance do not be linked up to the electrical system with an extension; extensions do not warrant the security of the appliance.
- The hob should not be installed over a dishwasher, a tumble dryer, a washing machine, a cooling, a freezing, an oven or an unprovide appliance fan cooling kitchen. On the one hand high release temperatures can damage these appliances, on the other hand in this way the ventilation of the hob is not ensured.

- The installation and the assembly of the hob in non-stationary places, like for example a ship, can be realized only by skilled technicians to guarantee safety during the functioning.
- If under the appliance there is a drawer, do not conserve flammable object inside of it (i.e. canisters).
- Make sure that after the installation, the hob electrical system connection wire is not subjected to mechanical stress, (i.e. doe to a drawer).
- The hob veneerings must be manufactured with thermoresistant adhesive (100°C), so they could not detach or bunckle. Also the back profiles must be thermoresistant.
- On one side and on the back side of an embedded ceramic hob there can be walls or furnitures of every height, while on the other side the furniture or an existing appliance must not be higher than the hob.

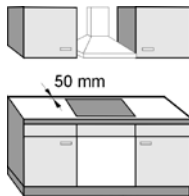

RECOMMENDED

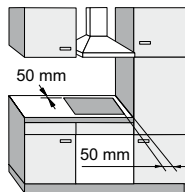

NOT RECOMMENDED

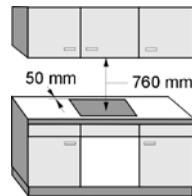

DISTANCE BETWEEN APPLIANCE AND HOOD

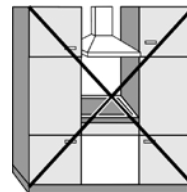

NOT RECOMMENDED

INSTALLATION

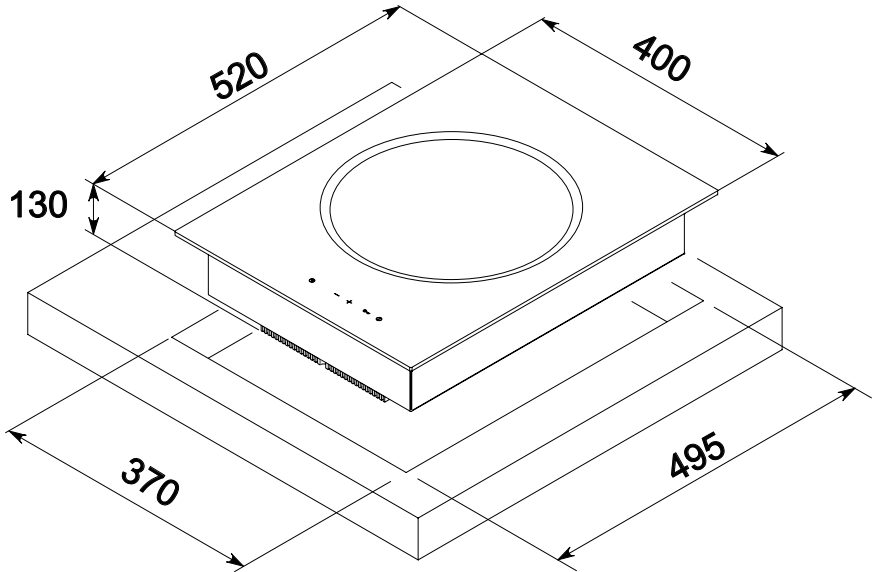

- Make the wood-carving on the work surface according to the model dimensions (see pictures above).
- Respect the minimal distance of 50 mm towards the back side and on the right and left towards a possible lateral wall.

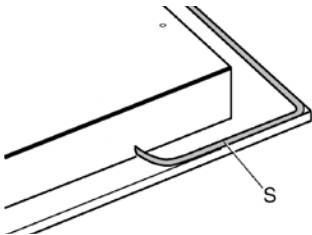

- Upset the hob and attach the washer, provided with the accessories kit, on the external side in an uniform way.
- So build in the hob in its worktop-out

INSTALLATION

ATTENTION:

To guarantee a correct functioning of the appliance it is important to provide the work surface, during the installation, of a 4mm chink for the length of the recess on the front side of the furniture.

This, because the electrical controls have a guard which, **if the electronic system overcome a 94°C temperature, switches off the hob until the temperature return under the limit.** So during the functioning, to guarantee a rush of air which maintains the right temperature, a fan start up.

Provide the assembling with an underlying cover which ensures the rush of air from the back side of the furniture or, if the hob is installed over an oven, a suitable insulation to guarantee that the temperature do not overcome 85°C.

If this happens there can be damages to the electronic system, for which the manufacturer do not have responsibilities.

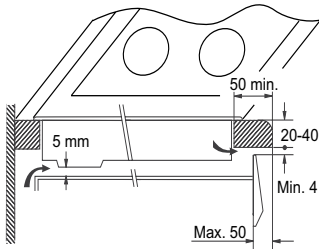

Electrical connection.

- The appliance must be installed by a qualified technician, who knows safety and assembling rules in force. In particular, local power institution rules must be observed.
- Check that the voltage indicated in the appliance indicator plate corresponds to the voltage used in your house. The indicator plate is placed in the back side of the hob.
- The grounding is compulsory according to the law. All the electric wires and grounding conductors should have appropriate dimensions.
- **The manufacturer declines all responsibility for damages on person or things caused by the non-observance of rules written above.**
- **The electrical connection between the hob and a possible embedding oven must be realized separated, whether for electrical safety reasons, or to simplify the extraction of the appliances.**

Before effecting the connection, make sure that:

- the outlet has the grounding and is made according to law;
- the outlet could bear the highest load of the machine, shown in the indicator placed on the appliance;
- the charging voltage is included in the characteristics indicator;
- the outlet is plug-compatible with the appliance. On the contrary replace the outlet or the plug; do not use extensions or multiplexes;
- the grounding wire (yellow/green coloured) is connected to the terminal board on the point indicated with the respective sign, and is longer than other conductor wires;
- the cable must not undergo foldings or compressions;
- the cable must be periodically controlled and changed only by authorized technicians.
- **the firm declines all responsibilities if these rules are not respected.**

In the case of a direct connection to the net, it is necessary to interpose a mono-pole switch between the appliance and the net, with a minimal 3mm opening between the contacts.

The installer is responsible of the right electrical connection and of the safety rules compliance.

START AND USE

Tips for cooking with the wok

The induction wok is eminently suitable for preparing “à la minute” dishes, in particular Chinese specialities. The food is continuously turned during the short frying time. The induction heating system means that in the wok you can cook extremely quickly and at high heat. As a result meat and fish remain succulent and vegetables retain colour, taste and vitamins.

Take care! Risks of burns from overheated fats and oils. The induction wok has – especially at heat setting 7 and above – a high power with extremely fast reaction time. Fat and oil overheat very quickly. When it starts to smoke, it is too hot. When cooking with fat or oil do not leave the appliance unattended.

The frying temperature can be estimated by testing with a wooden spoon. Hold the handle of a wooden spoon in the hot fat:

- If small bubbles rise to the surface, the frying temperature has been reached.
- If there are no bubbles, the frying temperature has not yet been reached.

Information on acrylamides

According to the latest scientific knowledge, intensive browning of food, especially in products containing starch, can constitute a health risk due to acrylamides. Therefore we recommend cooking at the lowest possible temperatures and not browning foods too much.

Handling the wok

- Place the wok pan into the wok niche carefully. If handled carelessly, the handle can hit the glass ceramic surface and damage it.
- Do not shake the wok pan while it is in the wok niche. The glass ceramic surface can be scratched or damaged by the handle.

Cookware for the induction wok - Suitability test

Cookware is suitable for induction cooking, if ...

- ... a magnet sticks to the bottom of the cookware.
- ... a little water on an induction cooking zone set to heat setting 9 is heated very quickly.

The cookware can make noises while working on induction cooking zones. These noises are not a fault in the appliance and do not affect operation in any way.

Cookware with a flat bottom must not be used.

START AND USE

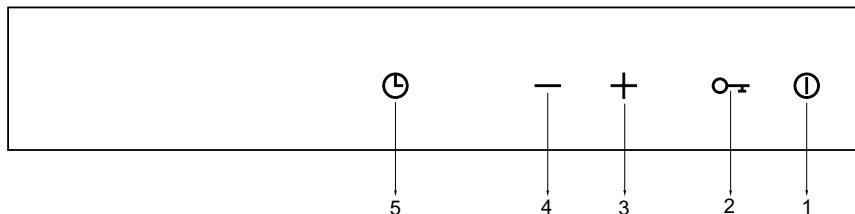

Switching on.

The control is switched on by pressing the on/off key (n°1). When this sensor is selected a sound is made. The heaters remain off (all the digits show 0) until a power level is selected. If the selection is not made in 10 seconds, and if the timers are off, the control turns off automatically.

With the control on, the first time the sensor (+) is pressed, the heater switches on at level 4.

The sensor (+) raises the cooking level to a maximum of 9, whereas the sensor (-) reduces the cooking level to 0 (heater off).

With the heater at position 0, the sensor (-) raises the cooking level to 9.

If the sensor is held down, the action is repeated twice every second.

Booster function

The cooking zone must be set to level 9. Once you set this value, by pressing the "+" button will activate the booster function. The display will show the letter "P".

Key function (lock)

Key lock

Holding the key lock sensor down turns the key lock function on or off. If the pilot light associated with the key lock sensor is on, the keypad is locked.

The locking function can be activated when the cooking levels are activated or when the cook top is off. If the cook top is on, the key lock function locks all the sensors except the general on/off sensor and the key lock. When the cook top is off, the key lock function locks all the sensors, including the general on/off, except the key lock.

Unlocking the keypad

If the keypad is locked (the pilot light associated with the key lock sensor is on), holding down the key lock sensor turns the key lock function off and the pilot light goes off.

START AND USE

Timer function

Activate the appliance and select the desired power level (it can also be changed as a result of activation function).

To activate the timer function is to press the sensor  and set the duration (in minutes, from 0 to 99) with the 'use of sensors (+) and (-). Pressing the sensor timer will turn on a red light above the 'display of power that confirms the' activation function.

When the time set an acoustic signal will alert the end of the function, just press a sensor to turn off the touch controls.

Automatic switch-off.

If the power level is not changed during a preset time, the corresponding heater turns off automatically. The maximum time a heater can stay on depends on the selected cooking level.

POWER LEVEL	MAX. TIME ON (Minutes)	ABSORBED POWER W (indicative)
1	520	300 (in steps of 4s)
2	402	300 (in steps of 3s)
3	318	300 (in steps of 2s)
4	260	300 (in steps of 1s)
5	212	350
6	170	600
7	139	900
8	113	1350
9	90	2300
P	10*	3000

* If you are using the booster function after 10 minutes the appliance will not switch off, but it go down to the level of power 9.



Pressing the heater keys (+) and (-) at the same time switches off the corresponding heater and the display shows the power level as 0. We can also switch off the heater by pressing the key (-) until the display shows the power level as 0.

General off

The general off function can be performed regardless of the operating mode of the cook top by pressing the on/off sensor. When the cook top is turned off, a beep sounds and the displays turn off, as long as an 'H' is not being shown on the corresponding display as a result of residual heat or an alarm.

PROBLEMS AND SOLUTIONS

What to do if ...

Problem	Possible cause	Remedy
The cooking zone cannot be switched on or is not operating	More than 10 seconds have passed since the appliance was switched on	Switch the appliance on again.
	The child safety device is switched on 	Deactivate child safety device (See the section "Child safety device")
	Several sensor fields were touched at the same time	Only touch one sensor field
	Automatic switch off has been triggered	Remove any objects (pan, cloths, etc.) that are lying on the control panel. Switch appliance on again
The residual heat indicator is not displaying anything	The cooking zone was only on for a short time and is therefore not hot	If the cooking zone is supposed to be hot, call the Customer Service Department.
 lights up	Unsuitable cookware	Use suitable cookware
	No cookware on the cooking zone	Put cookware on zone
It is very hard to adjust the heat settings	Potential differences	Do not touch the pan handle when setting the heat settings and do not position over the control panel.

If you are unable to remedy the problem by following the above suggestions, please contact your local Service Centre.

Warning! Repairs to the appliance are only to be carried out by qualified service engineers. Considerable danger to the user may result from improper repairs. 3 If the appliance has been operated incorrectly, the engineer's visit will be chargeable, even during the warranty period.

CARE AND CLEANING

Never use vapour machines to clean. On the one hand the vapour can reach electrical conductor components and cause a short-circuit. On the other hand vapour pressure can cause permanent damages on the surfaces and on the appliance components; the manufacturer is not responsible of these damages.

Do not use pointed objects, as not to damage washers between ceramic and frame and between frame and working surface.

Do not use products with sands, alkali, acids or chlorides, oven spray, detergents used to clean dishwashers, steel wool or abrasive dampers or a hard bristle brush. Do not use also dampers or other products which have abrasive detergents residuals because they could scratch the surface.

Pay attention to the detergent used to clean the ceramic because if it is not the right one, it could bleach the surface; it could appear permanent blue stains.

Use special detergent for ceramic.

Eliminate from the cooking zones with a wet cloth all detergent rests used to clean the ceramic; if the cooking zones are reinserted, these substances could damage the ceramic.

For this reason, clean immediately all dirty residues so that they do not burn. Make sure that pots bottom is clean, dry and without grease before putting the dishes in the hob.

Do not put metallic objects on the hob, like for example knives, spoones, covers and so on.

Always blot the appliance after pass it with a wet cloth to avoid the formation of calcareous rests.

Clean the appliance regularly, always after use it. Before the cleaning, wait till the hob is cold.

Eliminate dirty with a wet cloth; if there are hard stains use the appropriate spatule.

At the end clean the hob with some drops of a special ceramic detergent and with kitchen paper or with a wet cloth. In this way also calcareous rests, caused by water overflowed during the cooking, and stains with metallic reflections (alluminium residuals) can be eliminated.

Clean the surface with a wet cloth and pass it with a clean one after finishing to use the hob.

So, clean the cooking zone when it cool down as described above.

The manufacturing firm refuses all responsibility for any possible imprecision in this booklet, due to misprints or clerical errors. It reserves the right to make all the changes that it will consider necessary in its own products, without affecting the essential characteristics of functionality and safety.