

MAGDALENA SINGLE LEVER KITCHEN TAP

CODE: MAGDALENA

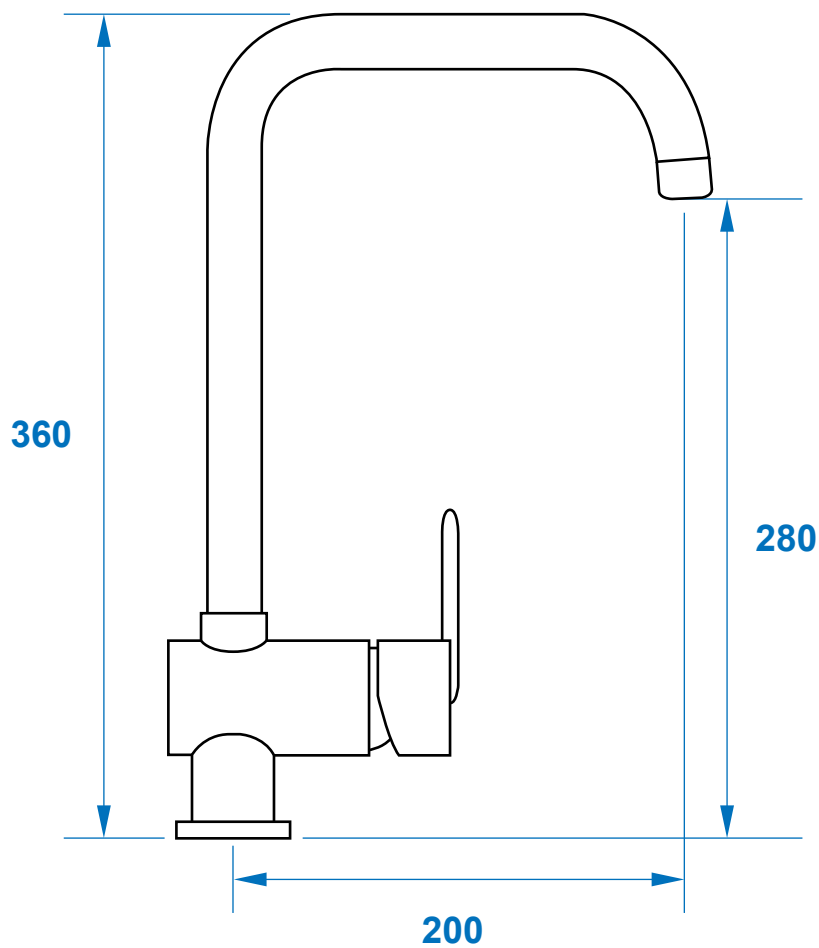



MAGDALENA SINGLE LEVER KITCHEN TAP

CODE: MAGDALENA

SPECIFICATION

Description	KITCHEN MIXER TAP WITH SINGLE LEVER CERAMIC DISC CARTRIDGE
Tap Hole Size	35 MM
Warranty	5 YEARS
Product Weight (kg)	2
Packed Weight (kg)	2.2
Packed Dimensions (mm)	410 X 245 X 60
Flow Rate @ 2.0 Bar	10 LPM
Pull out spray	NO
Rotation of the spout	360°
Finishes available	CHROME